



THE
SPRAY NOZZLE
PEOPLE

D3000

Rotary Jet
Tank Cleaner



TANK WASH

DESIGN FEATURES

- ✓ Entirely fluid driven meaning no external power source is required
- ✓ Fully sealed gear box allowing for muds and other high particulate fluids to be used as the cleaning media e.g. final effluent
- ✓ Stainless steel rugged design means almost no maintenance is required

TECHNICAL INFORMATION

- ✓ Flow rates: 130 - 560 L/min
- ✓ Working Pressure: 6 - 10 bar
- ✓ Spray pattern: 360°
- ✓ Jet length: Up to 16.9 metres
- ✓ Cycle times: Various available
- ✓ Materials:
 - Body: 316L
 - Gears: PEEK
 - Bushings: Carbon Filled PTFE
- ✓ Max height: 241 mm
- ✓ Max width: 150mm
- ✓ Weight: 11kg
- ✓ Operating temp: Up to 100°
- ✓ Inlet: 1.5" BSP/
PN10/40 Flange



The D3000 is suitable for vessels up to 30,000 DWT and is approved by Bureau Veritas.

It has wash-lubricated bearings which remove the possibility of cargo contamination by gearbox lubricants. There is an option to have a grease lubricated gearbox if required.

A "Full Tank - Quick Rinse" facility is built into the machine mechanism.

A combination of nozzle sizes and cycle times allows the D3000 to be tailor made to suit particular applications.

The D3000 can be supplied as a fixed, permanently installed unit or as a portable machine.

CALL NOW : +44 (0) 1273 400092

www.spray-nozzle.co.uk

The Go-to People for spray nozzle solutions

How it works

The D3000 is a fluid driven rotary jet cleaner. The cleaning fluid is pumped through the machine and this first passes through a turbine which causes the two nozzle arms to spin. The fluid then passes through the nozzles forming a powerful cleaning jet. As the arms rotate the main body also rotates in a set pattern. This is geared so that over a specific period of time (the clean cycle) the cleaning jets are brought to bear on each part of the tank ensuring a thorough, methodical clean.

For each configuration of D3000 there will a maximum jet length for any given fluid pressure. The max jet length is the overall reach of the resulting spray. The effective cleaning jet length is smaller than this and represents the distance from the machine where a reasonable cleaning action will be achieved. Clearly a more robust clean will be given the further within the effective jet length the target sits.

Made in the UK



The D3000 is manufactured in the UK exclusively for The Spray Nozzle People by Dasic Marine

BV approved



Certificate number: 07354/E0 BV
File number: ACM 179/0401/007
Productcode:8111H

Shaping a World of Trust

Portable Machine

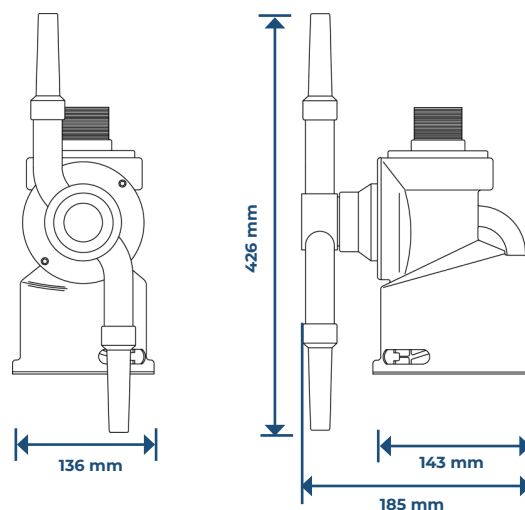

Fixed Machine

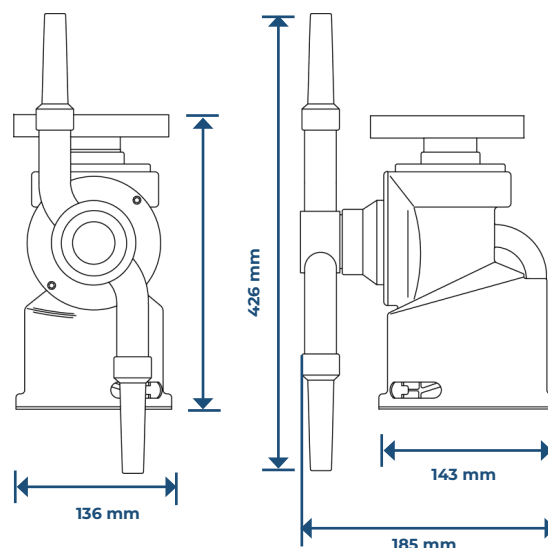

D3000 Flow rates, & jet lengths

Bar	Nozzle Size											
	2x6mm		2x7mm		2x8mm		2x9mm		2x10mm		2x12.5mm	
	Flow Rate l/min	Jet Length m	Flow Rate l/min	Jet Length m	Flow Rate l/min	Jet Length m	Flow Rate l/min	Jet Length m	Flow Rate l/min	Jet Length m	Flow Rate l/min	Jet Length m
6	130	11.6	153.3	12.8	210	12.9	241.7	13.9	270	14.2	440	15.5
8	160	13	200	14	250	14.3	283.3	15	320	15.7	520	16.2
10	170	14.5	230	14.9	270	15.2	316.7	15.8	365	16.5	560	16.9