



THE
SPRAY NOZZLE
PEOPLE

D4000

Rotary Jet
Tank Cleaner



TANK WASH

DESIGN FEATURES

- ✓ Entirely fluid driven meaning no external power source is required
- ✓ Fully sealed gear box allowing for muds and other high particulate fluids to be used as the cleaning media e.g. final effluent
- ✓ Stainless steel rugged design means almost no maintenance is required

TECHNICAL INFORMATION

- ✓ Flow rates: 433.3 - 866.7 L/min
- ✓ Working Pressure: 6 - 10 bar
- ✓ Spray pattern: 360°
- ✓ Jet length: 16.5 to 25.5 metres
- ✓ Cycle times: Various available
- ✓ Materials:
 - Body: 316L
 - Gears: PEEK
 - Bushings: Carbon Filled PTFE
- ✓ Max height: 265 mm
- ✓ Max width: 165mm
- ✓ Weight: 14kg
- ✓ Operating temp: Up to 100°
- ✓ Inlet: 2.5" BSP Male/
PN16/50 Flange



The D4000 was developed to meet the demands of the increasing size of chemical and product carrier tonnage.

The D4000 is suitable for vessels up to 50,000 DWT and is approved by Bureau Veritas.

All main components of the D4000 are manufactured in Stainless Steel (AISI 316L) whilst all seals and gearing are manufactured in resilient materials ensuring compatibility with a wide range of chemical / product cargos.

The D4000 is lubricated by the wash media which removes the possibility of cargo contamination by gearbox lubricants. A range of nozzle sizes allows the machine to be tailored to suit your particular requirements.

The D4000 can be supplied as a fixed, permanently installed unit or as a portable machine.

CALL NOW : +44 (0) 1273 400092

www.spray-nozzle.co.uk

The Go-to People for spray nozzle solutions

How it works

The D4000 is a fluid driven rotary jet cleaner. The cleaning fluid is pumped through the machine and this first passes through a turbine which causes the two nozzle arms to spin. The fluid then passes through the nozzles forming a powerful cleaning jet. As the arms rotate the main body also rotates in a set pattern. This is geared so that over a specific period of time (the clean cycle) the cleaning jets are brought to bear on each part of the tank ensuring a thorough, methodical clean.

For each configuration of D4000 there will be a maximum jet length for any given fluid pressure. The max jet length is the overall reach of the resulting spray. The effective cleaning jet length is smaller than this and represents the distance from the machine where a reasonable cleaning action will be achieved. Clearly a more robust clean will be given the further within the effective jet length the target sits.

Portable Machine

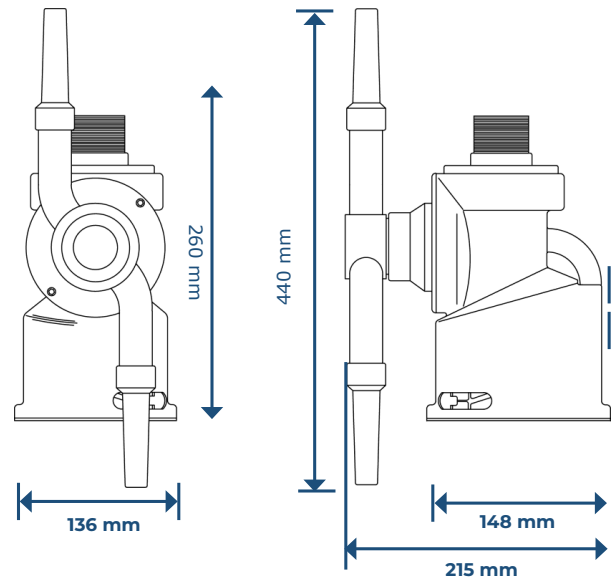

Fixed Machine

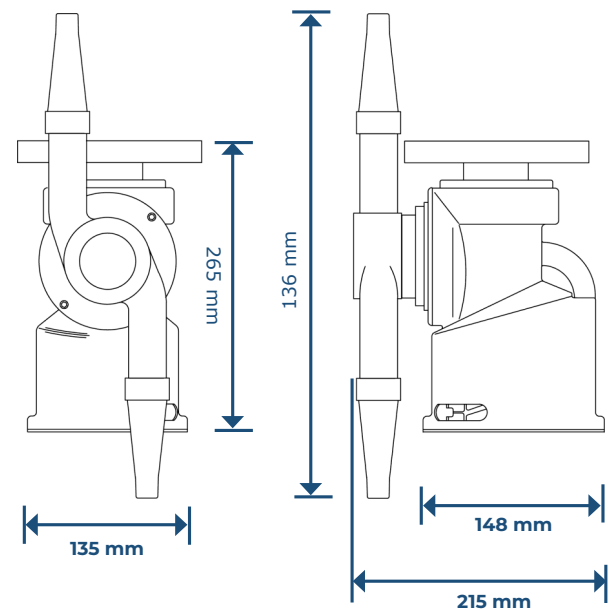

D4000

Flow rates, & jet lengths

Bar	Nozzle Size					
	2x12.5mm		2x14mm		2x16mm	
Flow Rate l/min	Jet Length m	Flow Rate l/min	Jet Length m	Flow Rate l/min	Jet Length m	
6	433.3	16.5	533.3	18.9	691.7	18.9
8	495	18.4	613.3	22.6	790	22.6
10	543.3	19.2	673.3	25.5	866.7	25.5

Made in the UK



The D4000 is manufactured in the UK exclusively for The Spray Nozzle People by Dasic Marine

BV approved



Certificate number: 11660/E0 BV
File number: ACM 179/0401/009
Product code: 8111H

Shaping a World of Trust