



THE
SPRAY NOZZLE
PEOPLE

HYDROWHIRL® MINI

Small Rotary Nozzle
Stainless Steel



TANK WASH

DESIGN FEATURES

- ✓ Fluid-driven, self-flushing
- ✓ Durable compact design, maintenance-free
- ✓ Made from FDA-compliant, 316L material
- ✓ Suitable for food applications
- ✓ PEEK slide-bearing for greater longevity
- ✓ Threads available: 3/8" NPT/BSP female

SPRAY CHARACTERISTICS

- ✓ Vigorous spray action
- ✓ Spray Angles: Complete 360° spray coverage, other spray angle patterns available upon request
- ✓ Flow Rates: 11.4 to 33.8 L/min
- ✓ Max Temperature: 130°C
- ✓ Filtration: Line strainer with a mesh size of 0.3mm/50 mesh

Contact us for additional connection types



The HydroWhirl® Mini tank cleaning nozzle directs the cleaning water through a rotating head at the tip of the spray assembly and produces a vigorous moving spray action against all areas of the tank wall.

The spray pattern from the HydroWhirl Mini® head uses impact and repetition to wash the tank quickly. Its compact size makes it ideal for food processing equipment cleaning including pipe and bottle cleaning and cleaning dispensing equipment.

CALL NOW : +44 (0) 1273 400092

www.spray-nozzle.co.uk

The Go-to People for spray nozzle solutions

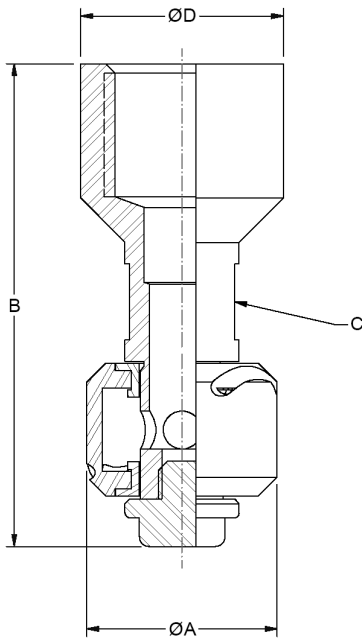

Threaded Version

DIMENSIONS IN MILLIMETRES (THREADED)

Pipe Size	A	B	C	D	Weight grams
3/8"	20.3	50.8	12.7	17.8	73.7

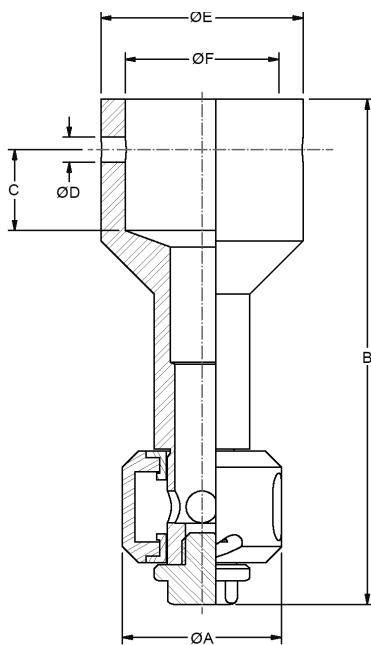

Clip-On Version

DIMENSIONS IN MILLIMETRES (CLIP-ON)

Tube Size	A	B	C	D	E	F	Weight grams
3/4"	20.3	63.5	10.2	25	25.4	20.3	31.1

HYDROWHIRL® MINI Flow Rates

Materials: 316L stainless steel body; slide-bearing PEEK

Female connection Type	Nozzle No	Spray Angles	Flow Rate (L/Min) @ Bar						Coverage Dia. @ 3 Bar m
			0.5 bar	0.7 bar	1 bar	2 bar	3 bar	4 bar	
3/8" NPT/BSP 3/4" Tube Clip-on	HVM 7.5	360°	11.4	13.6	16.4	23.5	29.1	33.8	1.8

*Flow rates represent threaded connections with a 360° spray angle.

*Flow rates may vary for other connection types and spray angles.