



THE
SPRAY NOZZLE
PEOPLE

HYDROWHIRL®
STINGER

Slotted Rotary Nozzle



TANK WASH

DESIGN FEATURES

- ✓ Patent-pending no-weld design eliminates weakpoints and uneven surfaces
- ✓ Bearing assembly is centered within the spray head for improved balance and spray propagation
- ✓ Better spray uniformity can be maintained at lower pressures
- ✓ Unique patent-pending pipe thread technology flushes
- ✓ to reduce contamination and bacteria growth
- ✓ Zirconia Ceramic Bearings for long service life and extreme chemical resistance
- ✓ Operates in any direction

SPRAY CHARACTERISTICS

- ✓ Self-cleaning bearings
- ✓ Vigorous moving spray action
- ✓ Spray Angles: 360°
- ✓ Flow rates: 4.15 – 380 l/min
- ✓ Recommended filtration: 150 mesh for HWS2-4 and smaller or 200 mesh for HWS2.75 and larger
- ✓ Max temp 93°C



The HWS2 tank cleaning head delivers a robust cleaning action to the entire vessel. It is fluid powered, with the rotary action driven by liquid pressure.

The HWS is manufactured in hygienic 316 stainless steel making it ideal for food and pharmaceutical cleaning applications. It is a suitable choice of tank cleaner for small-medium sized vessels with light to moderately tough residues.

CALL NOW : +44 (0) 1273 400092

www.spray-nozzle.co.uk

The Go-to People for spray nozzle solutions

HydroWhirl Stinger flow rate and coverage data

Nozzle Number	Female Connection Types	Spray Angles	Flow Rate (LPM) @ Pressure					Maximum Free Passage	Coverage Dia (m) @ 2 bar
			0.7 bar	1 bar	2 bar	3 bar	4 bar		
HWS2-2.1	1/8" FNPT, BSP 3/8" Tube Clip-On	360°	4.15	4.92	6.83	8.27	9.48	0.64	0.6
HWS2-4			7.8	9.27	13	15.8	18.1	0.99	2
HWS2-7.5			14.6	17.4	24.3	29.6	34	1.6	2
HWS2-10	3/8" FNPT, BSP 1/2" Tube Clip-On	360°	18.8	22.6	32.1	39.5	45.7	0.61	2
HWS2-12			23.7	28.1	39	47.3	54.2	0.99	3
HWS2-17			32.8	39.1	54.9	67.1	77.3	2	3
HWS2-20	1/2" FNPT, BSP	360°	39	46.3	64.8	78.9	90.6	0.99	3
HWS2-26			49	58.8	83.6	103	119	1.63	3
HWS2-20	3/4" FNPT, BSP 3/4" Tube Clip-On	360°	39	46.3	64.8	78.9	90.6	0.99	3
HWS2-26			49	58.8	83.6	103	119	1.63	3
HWS2-33	1" FNPT, BSP 1" Tube Clip-On	360°	63.5	75.7	107	130	150	0.79	3
HWS2-55			105	126	177	217	251	1.63	4
HWS2-66			127	152	213	260	300	2.39	4
HWS2-84			165	195	272	331	380	3.18	4

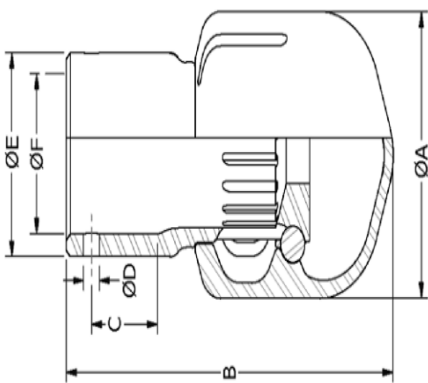

HWS2 dimenisons (Tube Clipon)

Tube Size	A	B	C	D	E	F	Weight (g)	Min Tank Entry Dia (mm)
1"	46.7	86.4	21.3	3.96	33.5	25.4	340	46.7
3/4"	34.3	72.2	12.7	2.18	26.9	19	198	34.3
1/2"	21.6	48.3	12.4	2.18	21.3	12.7	85	30.2
3/8"	15.2	34.9	8.61	2.18	14.2	9.52	23	22.9

HWS2 Weights and dims (threaded)

Pipe Size	A	B	E	Weight (grams)	Min Tank Entry Dia
1"	46.7	80	36.6	298	46.7
3/4"	34.3	69.1	29.2	146	34.3
1/2"	34.3	60.3	24.1	134	34.3
3/8"	21.6	45.2	19.1	40	21.6
1/8"	15.2	31.7	12.8	28	15.2

