

# Lafferty Equipment Manufacturing, Inc. Installation & Operation Instructions

Model # 950700 · Portable 5 Gallon 633 4-Way Fogger

## REQUIREMENTS

Ready-to-Use Chemical Solution

**Compressed Air** up to 15 CFM @ 80 PSI

**Minimum Air Supply Line** 1/2"

## OPTIONS

**Square Jug Rack Conversion**

Specify Round or Square Jug Racks at time of order

**5 Gallon Pail**

Pail, 5 Gallon Round W/ Suction Stem # 709105

**For Lighter Fog Use Metering Tips (4 Sets)**

Metering Tips-Color Coded (10 Smallest) # 443794

**Optional Check Valves to Keep Tubes Primed**

Check Valve, Chemical, PP(W), 1/4" (EPDM) # 491401

## WEIGHT & DIMENSIONS

**Single Package**

Shipping Weight 41 lbs.

Shipping Dimensions 43" x 26" x 16"



**Lafferty**  
EQUIPMENT MANUFACTURING INC.

[www.laffertyequipment.com](http://www.laffertyequipment.com)

501-851-2820

**WARNING! READ ALL  
INSTRUCTIONS BEFORE  
USING EQUIPMENT!**



## OVERVIEW

The Portable 5 Gallon 633 4-Way Fogger is a chemical atomizer that uses compressed air (15 CFM @ 80 PSI) and venturi action to draw ready-to-use chemical solution from a user-supplied chemical pail on the all stainless steel cart. It will atomize the solution and project it as small to medium sized fog particles in 4 directions up to 15 feet. This unit features a telescoping mast and can also be used as a 2-Way fogger.

**SAFETY & OPERATIONAL PRECAUTIONS**

- Manufacturer assumes no liability for the use or misuse of this unit.
- Wear proper respiratory protection, protective clothing, gloves and eye-wear when working with chemicals.
- Always direct the discharge away from electrical devices.
- Follow the chemical manufacturer's safe handling instructions.
- Carefully follow chemical manufacturer's safe handling instructions and recommended precautions/practices when using flammable chemicals.
- **SPECIAL CAUTION: This fogger atomizes chemical into the air. Ensure that the area to be fogged has been evacuated of all people without proper respiratory protection!**

**TO INSTALL (REFER TO DIAGRAM ON NEXT PAGE)**

1. Unpack and connect the 4-way fogger head to the nipples and through the slide brackets as shown in the drawing
2. Push the pick up tubes over the 4 blue metering tip holders. Make sure to place the same tube on the 2 foggers with the ball valves. This allows the unit to be used as a 2 way.
3. Use a container with enough water for doing some test runs to familiarize yourself with the fogger before running chemicals through it. This will help you determine the best placement for the best coverage.
4. Place the fogger in the center of the test area to be fogged.
5. Place the 2 pick up tubes/strainers in the water.
6. Connect a 1/2" minimum air line to the fogger that has a shut off valve on the opposite end where the fogger can be turned on and off at a distance. Wear ear protection.
7. Loosen the anchor bolts on the slide brackets and raise the 4-way fogger assembly to preferred height, and tighten the bolts to secure.
8. Move away from the fogger and turn on your air supply, observe the foggers performance. The fog should be consistent and uniform. If it is sputtering and inconsistent you may need to partially close your airline ball valve to fine tune the air volume/pressure.
9. For certain applications the foggers may produce more volume than needed. If fog is too dense, optional metering tips are available for restricting the solution volume to produce a lighter fog
10. Observe the coverage, you may have to move the fogger a time or two for best coverage. Once you are familiar with coverage and operation and air flow adjustments you are ready to fog.

**TO OPERATE**

**SPECIAL CAUTION: This fogger atomizes chemical into the air. Ensure that the chemical is safe to be around or the area to be fogged has been evacuated of all people and/or animals before starting fogging. Upon completion of fogging, ensure that sufficient time has elapsed for all the fog to have dissipated before returning to the area without proper respiratory protection.**

1. Fill a 5 gallon pail with the desired amount of ready to use solution you want to "fog" and place the tubes in the chemical solution.
2. Place the fogger in the center of the area to be fogged.
3. Loosen the anchor bolts on the slide brackets and raise the 4-way fogger assembly to preferred height, and tighten the bolts to secure.
4. Connect your 1/2" minimum air line to the fogger do not turn on!!
5. Make sure you are out of the area to be fogged and turn on your air supply. Adjust airline ball valve if needed based on your testing with water.
6. For certain applications the foggers may produce more volume than needed. If fog is too dense, optional metering tips are available for restricting the solution volume to produce a lighter fog
7. Fogger will continue to run until the air supply is manually turned off.
8. Depending on the application, you will have to experiment with the amount of time and solution required to achieve the desired results.
9. Turn air supply off when finished. Do NOT re enter room without proper respiratory protection until fog dissipates.

**PORTABLE 633 4-WAY FOGGER**

PROJECT MEDIUM TO SMALL FOG

PARTICLES UP TO 15 FEET.

**COMPRESSED AIR FLOW (CFM)**

PLUMES	60 PSI	80 PSI
4-Way	12.0	15.0

**CHEMICAL SOLUTION DRAW RATE (FL-OZ/MIN)**

DISTANCE	60 PSI	80 PSI
80" Above Chemical	25.0	32.0
60" Above Chemical	31.0	37.0

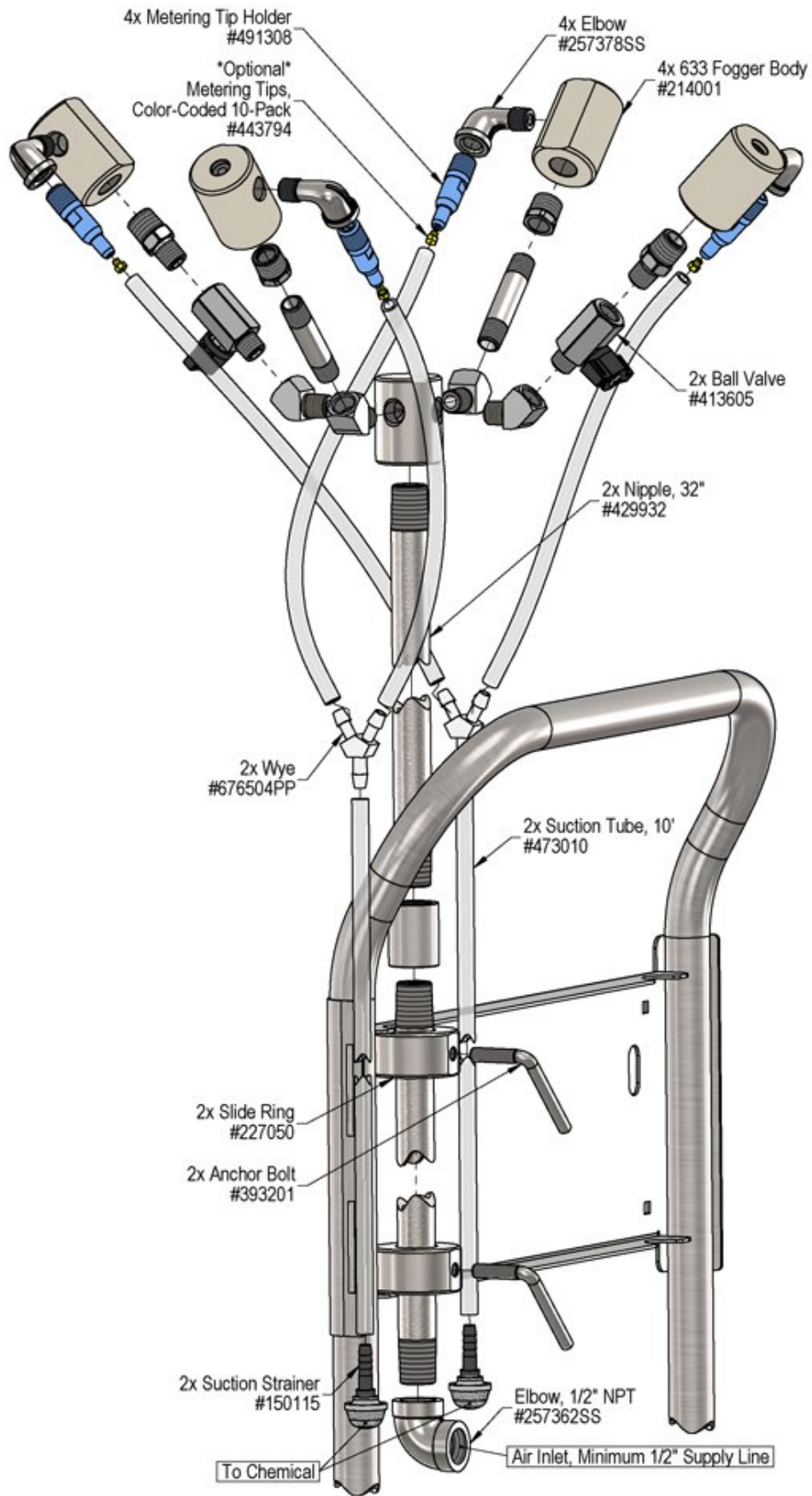

## Troubleshooting Guide

Problem	Possible Cause / Solution	
	Startup	Maintenance
A) Fogger will not draw chemical or is sputtering	1, 2, 3, 4	6, 7, 8, 9
B) Fog is too wet	1, 5	

Possible Cause / Solution	
Startup	Maintenance
<ol style="list-style-type: none"> <li><b>1. Air line too small, not enough air pressure or volume</b> <ul style="list-style-type: none"> <li>◦ See REQUIREMENTS, page 1.</li> </ul> </li> <li><b>2. Air pressure too high.</b> <ul style="list-style-type: none"> <li>◦ Slightly close the air supply valve to lower the pressure by lowering the volume until the fogger smooths out.</li> </ul> </li> <li><b>3. Fogger too high to draw chemical, 12' maximum</b> <ul style="list-style-type: none"> <li>◦ Raise the level of the chemical</li> </ul> </li> <li><b>4. Chemical tube kinked or not immersed in chemical or chemical depleted.</b> <ul style="list-style-type: none"> <li>◦ Straighten tube / replenish chemical</li> </ul> </li> <li><b>5. Drawing too much solution</b> <ul style="list-style-type: none"> <li>◦ Order and install optional metering tip or needle valve (needle valve 4 &amp; 8-Way only).</li> </ul> </li> </ol>	<ol style="list-style-type: none"> <li><b>6. Pin hole or cut in suction tube</b> <ul style="list-style-type: none"> <li>◦ Replace suction tube.</li> </ul> </li> <li><b>7. Chemical strainer clogged up</b> <ul style="list-style-type: none"> <li>◦ Clean or replace</li> </ul> </li> <li><b>8. Metering tip or metering tip holder clogged</b> <ul style="list-style-type: none"> <li>◦ Clean or replace metering tip and/or metering tip holder.</li> </ul> </li> <li><b>9. Debris clogging the fogger inlet jets</b> <ul style="list-style-type: none"> <li>◦ Disconnect air supply, remove fogger bodies and visually inspect; remove debris from fogger inlet.</li> </ul> </li> </ol>

**PREVENTIVE MAINTENANCE:** When the unit will be out of service for extended periods, place chemical tube(s) in water and flush the chemical out of the unit to help prevent chemical from drying out and causing build-up. Periodically check and clean chemical strainer and replace if missing.



# Lafferty Equipment Manufacturing, Inc. Installation & Operation Instructions

Model # 950701 · Portable 5 Gallon 305 4-Way Fogger

## REQUIREMENTS

Ready-to-Use Chemical Solution

Compressed Air up to 29.5 CFM @ 80 PSI

Minimum Air Supply Line 1/2"

## OPTIONS

Square Jug Rack Conversion

Specify Round or Square Jug Racks at time of order

For Lighter Fog Use Metering Tips (4 Sets)

Metering Tips-Color Coded (10 Smallest) # 443794

5 Gallon Pail

Pail, 5 Gallon Round W/ Suction Stem # 709105

Optional Check Valves to Keep Tubes Primed

Check Valve, Chemical, PP(W), 1/4" (EPDM) # 491401

## WEIGHT & DIMENSIONS

Single Package

Shipping Weight 41 lbs.

Shipping Dimensions 16" x 26" x 43"



**Lafferty**  
EQUIPMENT MANUFACTURING INC.

[www.laffertyequipment.com](http://www.laffertyequipment.com)

501-851-2820

**WARNING! READ ALL  
INSTRUCTIONS BEFORE  
USING EQUIPMENT!**



## OVERVIEW

The Portable 5 Gallon 305 4-Way Fogger is a chemical atomizer that uses compressed air (29.5 CFM @ 80 PSI) and venturi action to draw ready-to-use chemical solution from a user-supplied chemical pail on the all stainless steel cart. It will atomize the solution and project it as light, "damp" fog particles in 4 directions up to 25 feet. This unit features a telescoping mast and can also be used as a 2-Way fogger.

**SAFETY & OPERATIONAL PRECAUTIONS**

- Manufacturer assumes no liability for the use or misuse of this unit.
- Wear proper respiratory protection, protective clothing, gloves and eye-wear when working with chemicals.
- Always direct the discharge away from electrical devices.
- Follow the chemical manufacturer's safe handling instructions.
- Carefully follow chemical manufacturer's safe handling instructions and recommended precautions/practices when using flammable chemicals.
- **SPECIAL CAUTION: This fogger atomizes chemical into the air. Ensure that the area to be fogged has been evacuated of all people without proper respiratory protection!**

**TO INSTALL (REFER TO DIAGRAM ON NEXT PAGE)**

1. Unpack and connect the 4-way fogger head to the nipples and through the slide brackets as shown in the drawing
2. Push the pick up tubes over the 4 blue metering tip holders. Make sure to place the same tube on the 2 foggers with the ball valves. This allows the unit to be used as a 2 way.
3. Use a container with enough water for doing some test runs to familiarize yourself with the fogger before running chemicals through it. This will help you determine the best placement for the best coverage.
4. Place the fogger in the center of the test area to be fogged.
5. Place the 2 pick up tubes/strainers in the water.
6. Connect a 1/2" minimum air line to the fogger that has a shut off valve on the opposite end where the fogger can be turned on and off at a distance. Wear ear protection.
7. Loosen the anchor bolts on the slide brackets and raise the 4-way fogger assembly to preferred height, and tighten the bolts to secure.
8. Move away from the fogger and turn on your air supply, observe the foggers performance. The fog should be consistent and uniform. If it is sputtering and inconsistent you may need to partially close your airline ball valve to fine tune the air volume/pressure.
9. For certain applications the foggers may produce more volume than needed. If fog is too dense, optional metering tips are available for restricting the solution volume to produce a lighter fog
10. Observe the coverage, you may have to move the fogger a time or two for best coverage. Once you are familiar with coverage and operation and air flow adjustments you are ready to fog.

**TO OPERATE**

**SPECIAL CAUTION: This fogger atomizes chemical into the air. Ensure that the chemical is safe to be around or the area to be fogged has been evacuated of all people and/or animals before starting fogging. Upon completion of fogging, ensure that sufficient time has elapsed for all the fog to have dissipated before returning to the area without proper respiratory protection.**

1. Fill a 5 gallon pail with the desired amount of ready to use solution you want to "fog" and place the tubes in the chemical solution.
2. Place the fogger in the center of the area to be fogged.
3. Loosen the anchor bolts on the slide brackets and raise the 4-way fogger assembly to preferred height, and tighten the bolts to secure.
4. Connect your 1/2" minimum air line to the fogger do not turn on!!
5. Make sure you are out of the area to be fogged and turn on your air supply. Adjust airline ball valve if needed based on your testing with water.
6. For certain applications the foggers may produce more volume than needed. If fog is too dense, optional metering tips are available for restricting the solution volume to produce a lighter fog
7. Fogger will continue to run until the air supply is manually turned off.
8. Depending on the application, you will have to experiment with the amount of time and solution required to achieve the desired results.
9. Turn air supply off when finished. Do NOT re enter room without proper respiratory protection until fog dissipates.

**PORTABLE 305 4-WAY FOGGER**

PRODUCE MEDIUM FOG PARTICLES AND PROJECT A LIGHTER, "DAMP" MIST UP TO 25 FEET.

**COMPRESSED AIR FLOW (CFM)**

PLUMES	60 PSI	80 PSI
4-Way	22.5	29.5

**CHEMICAL SOLUTION DRAW RATE (FL-OZ/MIN)**

DISTANCE	60 PSI	80 PSI
80" Above Chemical	31.6	39.5
60" Above Chemical	37.4	44.2

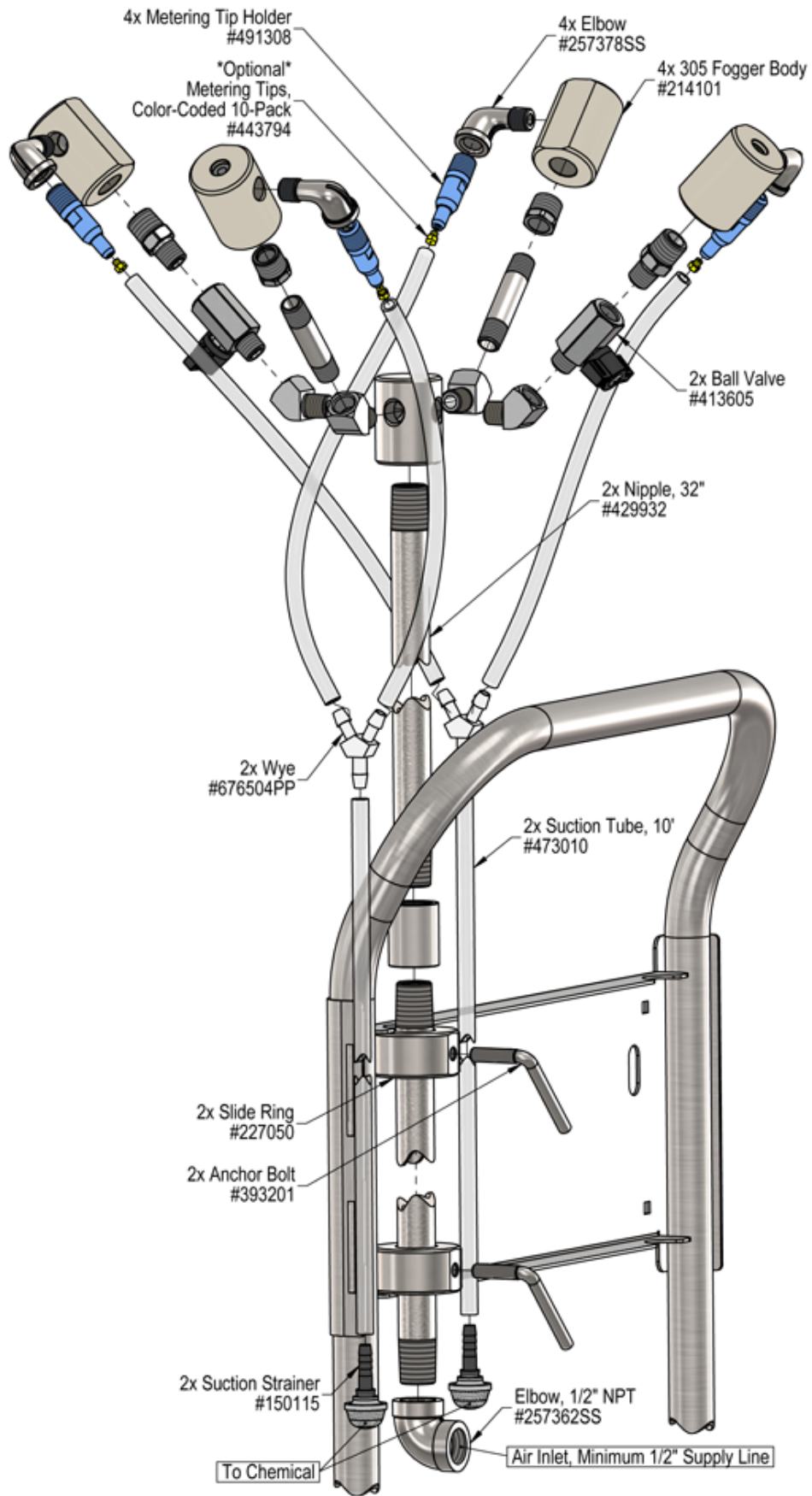

## Troubleshooting Guide

Problem	Possible Cause / Solution	
	Startup	Maintenance
A) Fogger will not draw chemical or is sputtering	1, 2, 3, 4	6, 7, 8, 9
B) Fog is too wet	1, 5	

Possible Cause / Solution	
Startup	Maintenance
<ol style="list-style-type: none"> <li><b>1. Air line too small, not enough air pressure or volume</b> <ul style="list-style-type: none"> <li>◦ See REQUIREMENTS, page 1.</li> </ul> </li> <li><b>2. Air pressure too high.</b> <ul style="list-style-type: none"> <li>◦ Slightly close the air supply valve to lower the pressure by lowering the volume until the fogger smooths out.</li> </ul> </li> <li><b>3. Fogger too high to draw chemical, 12' maximum</b> <ul style="list-style-type: none"> <li>◦ Raise the level of the chemical</li> </ul> </li> <li><b>4. Chemical tube kinked or not immersed in chemical or chemical depleted.</b> <ul style="list-style-type: none"> <li>◦ Straighten tube / replenish chemical</li> </ul> </li> <li><b>5. Drawing too much solution</b> <ul style="list-style-type: none"> <li>◦ Order and install optional metering tip or needle valve (needle valve 4 &amp; 8-Way only).</li> </ul> </li> </ol>	<ol style="list-style-type: none"> <li><b>6. Pin hole or cut in suction tube</b> <ul style="list-style-type: none"> <li>◦ Replace suction tube.</li> </ul> </li> <li><b>7. Chemical strainer clogged up</b> <ul style="list-style-type: none"> <li>◦ Clean or replace</li> </ul> </li> <li><b>8. Metering tip or metering tip holder clogged</b> <ul style="list-style-type: none"> <li>◦ Clean or replace metering tip and/or metering tip holder.</li> </ul> </li> <li><b>9. Debris clogging the fogger inlet jets</b> <ul style="list-style-type: none"> <li>◦ Disconnect air supply, remove fogger bodies and visually inspect; remove debris from fogger inlet.</li> </ul> </li> </ol>

**PREVENTIVE MAINTENANCE:** When the unit will be out of service for extended periods, place chemical tube(s) in water and flush the chemical out of the unit to help prevent chemical from drying out and causing build-up. Periodically check and clean chemical strainer and replace if missing.





# Lafferty Equipment Manufacturing, Inc. Installation & Operation Instructions

Model # 950721 · Portable 20 Gallon 305 4-Way Fogger

## REQUIREMENTS

Ready-to-Use Chemical Solution

Compressed Air up to 29.5 CFM @ 80 PSI

Minimum Air Supply Line 1/2"

## OPTIONS

Optional Check Valves to Keep Tubes Primed

Check Valve, Chemical, PP(W), 1/4"  
(EPDM) # 491401

For Lighter Fog Use Metering Tips (4 Sets)

Metering Tips-Color Coded (10  
Smallest) # 443794

Proportioning / Filling Options

1-Way Ball Valve Mixing Station (4  
GPM) # 985100

1-Way Push Lever Mixing Station (4  
GPM) # 981100

High Volume Mixing Station (9.9 GPM) # 985835

## WEIGHT & DIMENSIONS

Single Package

Shipping Weight 66 lbs.

Shipping Dimensions 48" x 26" x 24"



**Lafferty**  
EQUIPMENT MANUFACTURING INC.

[www.laffertyequipment.com](http://www.laffertyequipment.com)

501-851-2820

**WARNING! READ ALL  
INSTRUCTIONS BEFORE  
USING EQUIPMENT!**



## OVERVIEW

The Portable 20 Gallon 305 4-Way Fogger is a chemical atomizer that uses compressed air (29.5 CFM @ 80 PSI) and venturi action to draw ready-to-use chemical solution from the tank on the all stainless steel cart. It atomizes the solution and projects it as light, "damp" fog particles in 4 directions up to 25 feet. This unit features a telescoping mast and can also be used as a 2-Way fogger.

**SAFETY & OPERATIONAL PRECAUTIONS**

- Manufacturer assumes no liability for the use or misuse of this unit.
- Wear proper respiratory protection, protective clothing, gloves and eye-wear when working with chemicals.
- Always direct the discharge away from electrical devices.
- Follow the chemical manufacturer's safe handling instructions.
- Carefully follow chemical manufacturer's safe handling instructions and recommended precautions/practices when using flammable chemicals.
- **SPECIAL CAUTION: This fogger atomizes chemical into the air. Ensure that the area to be fogged has been evacuated of all people without proper respiratory protection!**

**TO INSTALL (REFER TO DIAGRAM ON NEXT PAGE)**

1. Unpack and connect the 4-way fogger head to the nipples and through the slide brackets as shown in the drawing
2. 4- pick up tube ends are sticking out of the tank lid, push them over the 4 blue metering tip holders. Make sure to place the same tube on the 2 foggers with the ball valves. This allows the unit to be used as a 2 way.
3. Use a separate container with enough water for doing some test runs to familiarize yourself with the fogger before running chemicals through it. This will help you determine the best placement for the best coverage.
4. Place the fogger in the center of the test area to be fogged.
5. Place the 2 pick up tubes/strainers in the water.
6. Connect a 1/2" minimum air line to the fogger that has a shut off valve on the opposite end where the fogger can be turned on and off at a distance. Wear ear protection.
7. Loosen the "L" bolts on the slide brackets and raise the fogger head assembly to preferred height, and tighten the bolts to secure.
8. Move away from the fogger and turn on your air supply, observe the foggers performance. The fog should be consistent and uniform. If it is sputtering and inconsistent you may need to partially close your airline ball valve to fine tune the air volume/pressure.
9. For certain applications the foggers may produce more volume than needed. If fog is too dense, optional metering tips are available for restricting the solution volume to produce a lighter fog
10. Observe the coverage, you may have to move the fogger a time or two for best coverage. Once you are familiar with coverage an operation and air flow adjustments you are ready to fog.

**TO OPERATE**

**SPECIAL CAUTION: This fogger atomizes chemical into the air. Ensure that the chemical is safe to be around or the area to be fogged has been evacuated of all people and/or animals before starting fogging. Upon completion of fogging, ensure that sufficient time has elapsed for all the fog to have dissipated before returning to the area without proper respiratory protection.**

1. Fill the 20 gallon tank with the desired amount of ready to use solution you want to "fog" and place the tubes in the chemical solution.
2. Place the fogger in the center of the area to be fogged.
3. Loosen the "L" bolts on the slide brackets and raise the fogger head assembly to preferred height, and tighten the bolts to secure.
4. Connect your 1/2" minimum air line to the fogger do not turn on!!
5. Make sure you are out of the area to be fogged and turn on your air supply. Adjust airline ball valve if needed based on your testing with water.
6. For certain applications the foggers may produce more volume than needed. If fog is too dense, optional metering tips are available for restricting the solution volume to produce a lighter fog
7. Fogger will continue to run until the air supply is manually turned off.
8. Depending on the application, you will have to experiment with the amount of time and solution required to achieve the desired results.
9. Turn air supply off when finished. Do NOT re enter room without proper respiratory protection until fog dissipates.

**PORTABLE 305 4-WAY FOGGER**

PRODUCE MEDIUM FOG PARTICLES AND PROJECT A LIGHTER, "DAMP" MIST UP TO 25 FEET.

**COMPRESSED AIR FLOW (CFM)**

PLUMES	60 PSI	80 PSI
4-Way	22.5	29.5

**CHEMICAL SOLUTION DRAW RATE (FL-OZ/MIN)**

DISTANCE	60 PSI	80 PSI
80" Above Chemical	31.6	39.5
60" Above Chemical	37.4	44.2

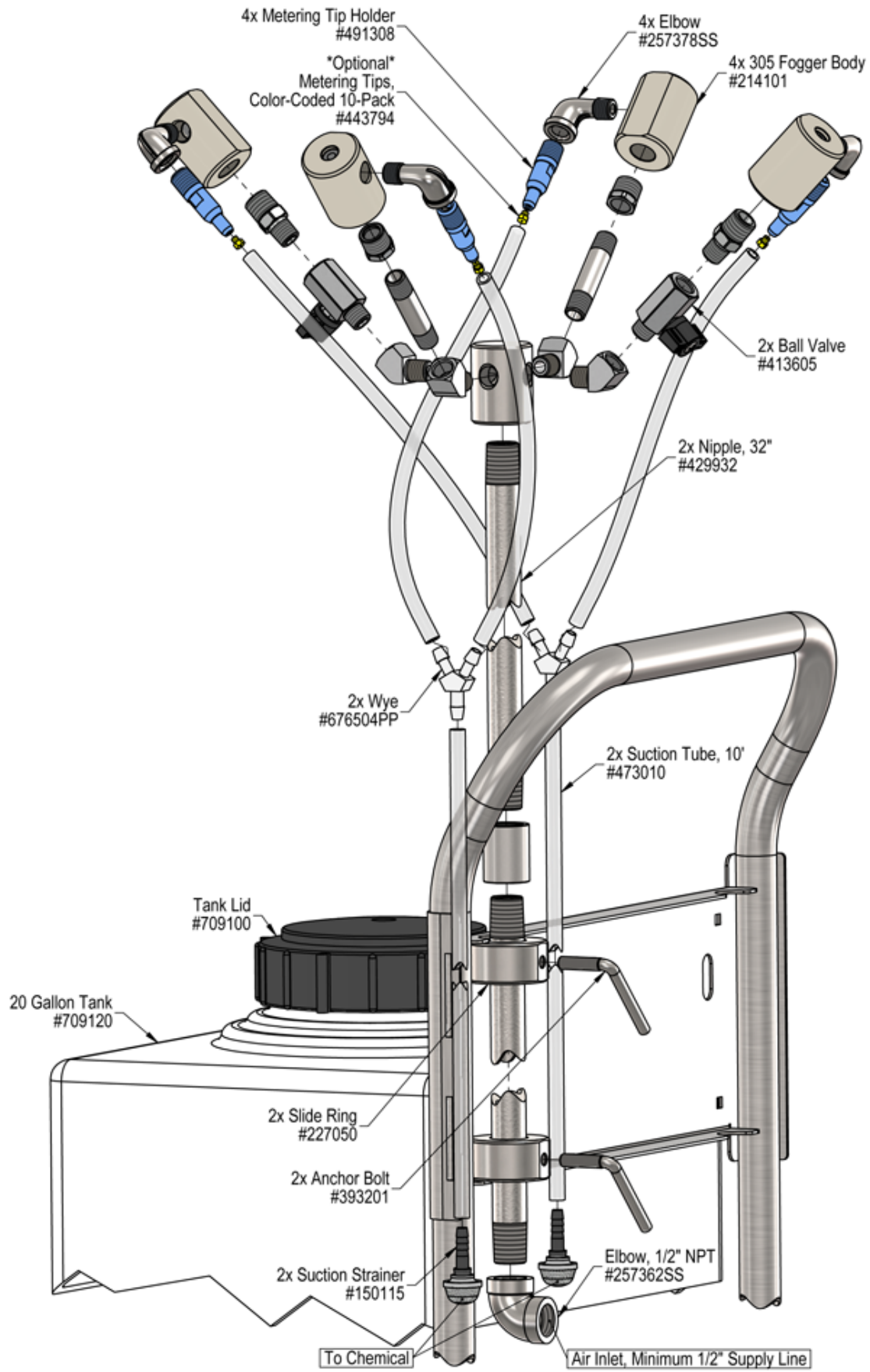

## Troubleshooting Guide

Problem	Possible Cause / Solution	
	Startup	Maintenance
A) Fogger will not draw chemical or is sputtering	1, 2, 3, 4	6, 7, 8, 9
B) Fog is too wet	1, 5	

Possible Cause / Solution	
Startup	Maintenance
<ol style="list-style-type: none"> <li><b>1. Air line too small, not enough air pressure or volume</b> <ul style="list-style-type: none"> <li>◦ See REQUIREMENTS, page 1.</li> </ul> </li> <li><b>2. Air pressure too high.</b> <ul style="list-style-type: none"> <li>◦ Slightly close the air supply valve to lower the pressure by lowering the volume until the fogger smooths out.</li> </ul> </li> <li><b>3. Fogger too high to draw chemical, 12' maximum</b> <ul style="list-style-type: none"> <li>◦ Raise the level of the chemical</li> </ul> </li> <li><b>4. Chemical tube kinked or not immersed in chemical or chemical depleted.</b> <ul style="list-style-type: none"> <li>◦ Straighten tube / replenish chemical</li> </ul> </li> <li><b>5. Drawing too much solution</b> <ul style="list-style-type: none"> <li>◦ Order and install optional metering tip or needle valve (needle valve 4 &amp; 8-Way only).</li> </ul> </li> </ol>	<ol style="list-style-type: none"> <li><b>6. Pin hole or cut in suction tube</b> <ul style="list-style-type: none"> <li>◦ Replace suction tube.</li> </ul> </li> <li><b>7. Chemical strainer clogged up</b> <ul style="list-style-type: none"> <li>◦ Clean or replace</li> </ul> </li> <li><b>8. Metering tip or metering tip holder clogged</b> <ul style="list-style-type: none"> <li>◦ Clean or replace metering tip and/or metering tip holder.</li> </ul> </li> <li><b>9. Debris clogging the fogger inlet jets</b> <ul style="list-style-type: none"> <li>◦ Disconnect air supply, remove fogger bodies and visually inspect; remove debris from fogger inlet.</li> </ul> </li> </ol>

**PREVENTIVE MAINTENANCE:** When the unit will be out of service for extended periods, place chemical tube(s) in water and flush the chemical out of the unit to help prevent chemical from drying out and causing build-up. Periodically check and clean chemical strainer and replace if missing.



# Lafferty Equipment Manufacturing, Inc. Installation & Operation Instructions

Model # 950721-TD · Portable Timed / Delay 20 Gallon 305 4-Way Fogger

## REQUIREMENTS

Ready-to-Use Chemical Solution

Compressed Air	up to 29.5 CFM @ 80 PSI
Minimum Air Supply Line	1/2"
Electric	120V

## OPTIONS

Optional Check Valves to Keep Tubes Primed

Check Valve, Chemical, PP(W), 1/4" (EPDM)	# 491401
---	----------

For Lighter Fog Use Metering Tips (4 Sets)

Metering Tips-Color Coded (10 Smallest)	# 443794
---	----------

Proportioning / Filling Options

1-Way Ball Valve Mixing Station (4 GPM)	# 985100
1-Way Push Lever Mixing Station (4 GPM)	# 981100
High Volume Mixing Station (9.9 GPM)	# 985835

## WEIGHT & DIMENSIONS

Single Package

Shipping Weight	74 lbs.
Shipping Dimensions	48" x 26" x 24"



**Lafferty**  
EQUIPMENT MANUFACTURING INC.

[www.laffertyequipment.com](http://www.laffertyequipment.com)

501-851-2820

**WARNING! READ ALL  
INSTRUCTIONS BEFORE  
USING EQUIPMENT!**



## OVERVIEW

The Portable Timed/Delay 20 Gallon 305 4-Way Fogger is a chemical atomizer that uses compressed air (29.5 CFM @ 80 PSI) and venturi action to draw ready-to-use chemical solution from the tank on the all stainless steel cart. It atomizes the solution and projects it as light, "damp" fog particles in 4 directions up to 25 feet. This unit features a telescoping mast and can also be used as a 2-Way fogger. An adjustable delay timer (up to 6 hours) allows the unit to be set to fog at a later time, and an adjustable run timer controls the length of time the unit will be fogging (up to 60 minutes).

**SAFETY & OPERATIONAL PRECAUTIONS**

- See Additional Safety Precautions included with the Electrical Control Box Installation Information
- Always consider electrical shock hazard when working with and handling electrical equipment. If uncertain, consult an Electrician. Electrical wiring should only be done by a qualified Electrician, per Local and State Electrical Codes.
- Manufacturer assumes no liability for the use or misuse of this unit.
- Wear proper respiratory protection, protective clothing, gloves and eye-wear when working with chemicals.
- Always direct the discharge away from electrical devices.
- Carefully follow chemical manufacturer's safe handling instructions and recommended precautions/practices especially when using flammable chemicals.
- For proper performance do NOT modify electrical control box.
- Disconnect electrical power to the control box prior to opening it.
- Remove any packing material from inside the control box before operating.
- **SPECIAL CAUTION: This fogger atomizes chemical into the air. Ensure that the chemical is safe to be around or the area to be fogged has been evacuated of all people and/or animals before starting fogging. Upon completion of fogging, ensure that sufficient time has elapsed for all the fog to have dissipated before returning to the area without proper respiratory protection.**

**TO INSTALL (REFER TO DIAGRAM ON NEXT PAGE)**

1. Unpack and connect the 4-way fogger head to the nipples as shown in the drawing
2. (4) pick up tube ends are sticking out of the tank lid, push them over the 4 blue metering tip holders. Place the same tube on the 2 foggers with the ball valves. This allows the unit to be used as a 2-way.
3. Test using water to familiarize yourself with the fogger before running chemicals through it.

**SETTING THE TIMER**

1. Make sure the system is not plugged in to a power source. Open the control box cover. The box contains one timer with both "Delay & Run" adjustment knobs.  
**Delay:** This mode allows you to set the length of time you want the unit to be inactive for before fogging begins. Set the timer by turning the knob to the amount of delay time that you require. (0-6 Hours)  
**Run:** This mode allows you to set the length of time you want the fogger to run for after the delay period has expired. Set the timer by turning the knob to the amount of run time that you require. (0-60 Minutes)
2. Close and lock the control box cover.
3. Plug the power cord into a 120 VAC power outlet. GFI recommended.

**SWITCH SETTINGS** (There are two lighted rocker switches on the front of the control box.)

1. The switch on the left is labeled "On/Off/Auto Ready". With the switch in the "Off" position there is no power to the unit and there are no lights illuminated. **Caution: If the switch is set to the "On" position, the green light is illuminated and the unit will automatically start fogging. This is useful during setup and testing with water. Otherwise this setting should be used with care.**
2. When the timers have been adjusted to required settings, the switch should be set to "Auto Ready". The red light illuminates and this provides power to the second switch on the right hand side of the control box.
3. The switch on the right is labeled "Auto Initiate". When you are ready to initiate the "Delay/Run" sequence, press the top of the switch to "Auto Initiate". The green light on this switch is now illuminated. The fogger is now in Delay mode and will perform according to preset times.

**Note:** If power is interrupted after timers have been set, the system stops all timer operations and needs to be reset.

**SETTING AND ADJUSTING FOG DENSITY**

1. Use a separate container of water to set and adjust the fog density. Place the pick-up tubes into the water.
2. Place the fogger in the center of the area to be fogged.
3. Loosen the "L"bolts on the slide brackets, raise the 4-way fogger assembly to preferred height, and tighten
4. Set the Delay Timer knob for a minimal amount of time (enough time for you to move away from the fogger) and set the Run Timer knob for about 1 minute (enough time for you to observe the fog density.)
5. Connect your 1/2" minimum air line to the fogger. Turn on your air and electricity supply.
6. Set the rocker switches on the control box as described above.
7. Move away from the fogger and observe the fogger's performance. **The fog should be consistent and uniform. If it is sputtering and inconsistent you may need to partially close your airline ball valve to fine tune the air volume/pressure. Best results are achieved at around 60 PSI.**
8. You will have to experiment with the amount of time and solution required to achieve the desired result.
9. If fog is more dense than the application requires, optional metering tips are available for restricting the solution volume to produce a lighter fog.
10. Once you are familiar with coverage, operation and air flow adjustments you are ready to fog.

**TO OPERATE**

1. Fill the tank with the desired amount of ready to use solution and insert the suction tubes in the tank.
2. With the fogger in the center of the area to be fogged and adjust fogger assembly to preferred height.
3. Set the timers to the desired Delay and Run times (see above).
4. Turn on your air and electricity supplies. Set the rocker switches as described above.
5. Turn air supply off when finished and ensure that the area is safe before returning

**PORTABLE 305 4-WAY FOGGER**

PRODUCE MEDIUM FOG PARTICLES AND  
PROJECT A LIGHTER, "DAMP" MIST UP TO 25  
FEET.

**COMPRESSED AIR FLOW (CFM)**

PLUMES	60 PSI	80 PSI
4-Way	22.5	29.5

**CHEMICAL SOLUTION DRAW RATE (FL-OZ/MIN)**

DISTANCE	60 PSI	80 PSI
80" Above Chemical	31.6	39.5
60" Above Chemical	37.4	44.2



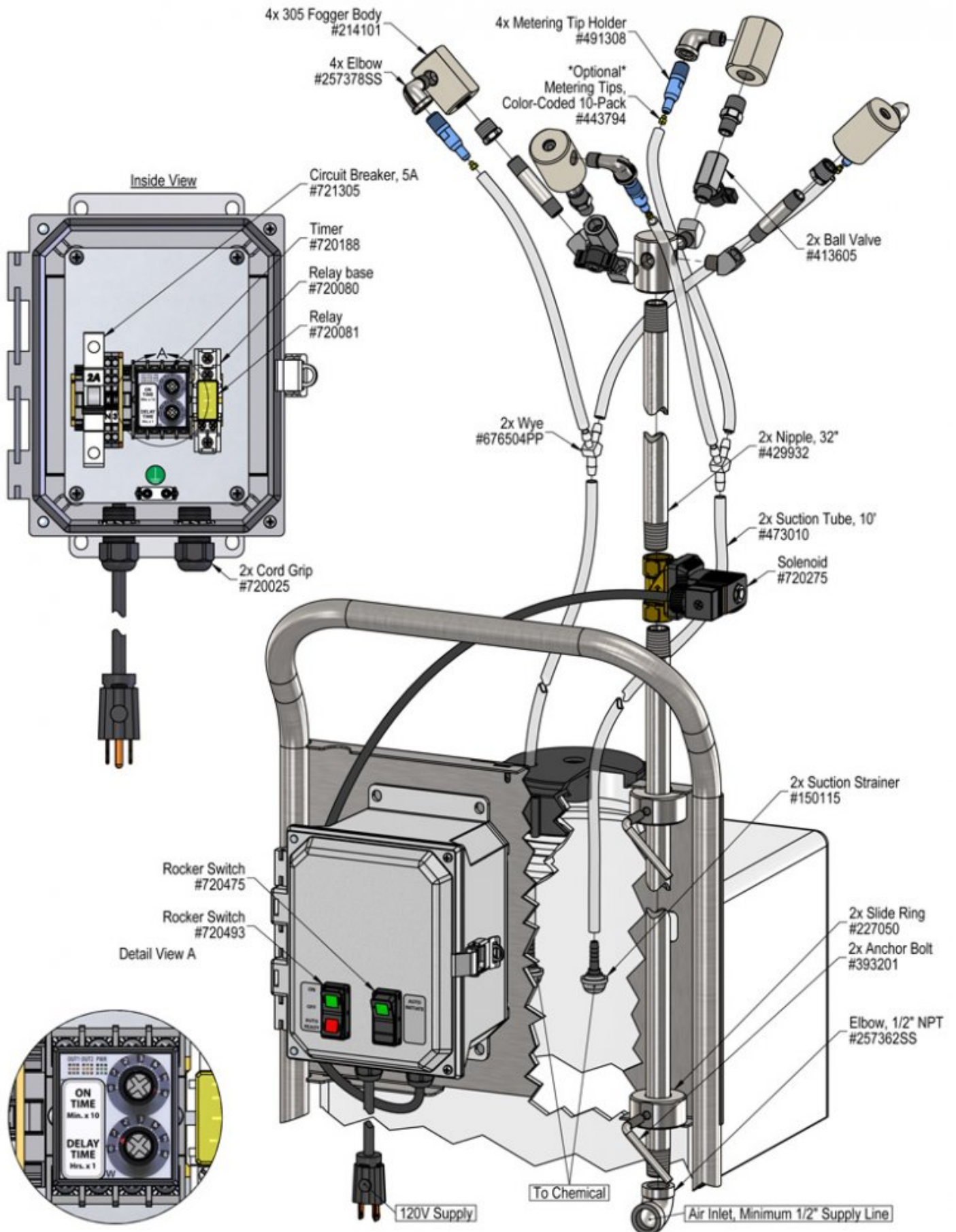

## Troubleshooting Guide

Problem	Possible Cause / Solution	
	Startup	Maintenance
A) Fogger will not draw chemical or is sputtering	1, 2, 3, 4	8, 9, 10, 11
B) Fog is too wet	1, 5	
C) Doesn't come on when switch is turned on.	6, 7	
D) Comes on and runs continuously.	6	

Possible Cause / Solution	
Startup	Maintenance
<ol style="list-style-type: none"> <li><b>1. Air line too small, not enough air pressure or volume</b> <ul style="list-style-type: none"> <li>◦ See REQUIREMENTS, page 1.</li> </ul> </li> <li><b>2. Air pressure too high.</b> <ul style="list-style-type: none"> <li>◦ Slightly close the air supply valve to lower the pressure by lowering the volume until the fogger smooths out.</li> </ul> </li> <li><b>3. Fogger too high to draw chemical, 12' maximum</b> <ul style="list-style-type: none"> <li>◦ Raise the level of the chemical</li> </ul> </li> <li><b>4. Chemical tube kinked or not immersed in chemical or chemical depleted.</b> <ul style="list-style-type: none"> <li>◦ Straighten tube / replenish chemical</li> </ul> </li> <li><b>5. Drawing too much solution</b> <ul style="list-style-type: none"> <li>◦ Order and install optional metering tip or needle valve (4 &amp; 8 Way only).</li> </ul> </li> <li><b>6. Timer failed</b> <ul style="list-style-type: none"> <li>◦ Replace timer.</li> </ul> </li> <li><b>7. May have electrical problems</b> <ul style="list-style-type: none"> <li>◦ Ensure circuit breaker (5 Amp) has not been tripped.</li> <li>◦ Have a qualified electrician check electrical connections.</li> </ul> </li> </ol>	<ol style="list-style-type: none"> <li><b>8. Pin hole or cut in suction tube</b> <ul style="list-style-type: none"> <li>◦ Replace suction tube.</li> </ul> </li> <li><b>9. Chemical strainer clogged up</b> <ul style="list-style-type: none"> <li>◦ Clean or replace</li> </ul> </li> <li><b>10. Metering tip or metering tip holder clogged</b> <ul style="list-style-type: none"> <li>◦ Clean or replace metering tip and/or metering tip holder.</li> </ul> </li> <li><b>11. Debris clogging the fogger inlet jets</b> <ul style="list-style-type: none"> <li>◦ Disconnect air supply, remove fogger bodies and visually inspect; remove debris from fogger inlet.</li> </ul> </li> </ol>

**PREVENTIVE MAINTENANCE:** When the unit will be out of service for extended periods, place chemical tube(s) in water and flush the chemical out of the unit to help prevent chemical from drying out and causing build-up. Periodically check and clean chemical strainer and replace if missing.

