

COMPLETE QUIK-DISCONNECT RISER ASSEMBLIES

- ◀ Direct to you from Uni-Spray, made exactly to your specifications and ready to install.
- ◀ We offer a full range of our own exclusive Quik-Disconnect components in a full range of sizes, including premium-quality PVC, CPVC, PolyPro, Kynar and stainless steel pipe.
- ◀ To give you total design flexibility, we can custom bend the pipework, providing smooth flow without extra fittings, to precisely meet your design configuration.
- ◀ To simplify your ordering process, we offer over 20 design configurations with separate worksheets for each. The worksheets allow you to enter all of the dimensions, design parameters, selection and positioning of components in a simple, fill-in-the-blank format.
- ◀ If you don't see exactly what you want, send us your own drawing for a quotation.
- ◀ When we receive your completed worksheet or drawing, our engineers will review it for accuracy, and we will provide with a detailed quote.

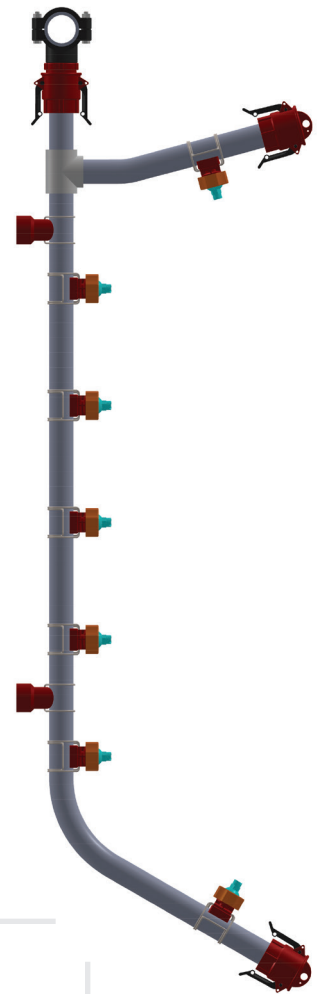

Exclusive to Uni-Spray, our formed risers eliminate the need for expensive glued couplers. In addition, smooth bends increase fluid flow and prevent material buildup.

QUIK-DISCONNECT RISERS - CONTACT US FOR A WORKSHEET

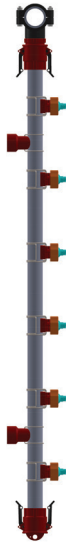

R1T

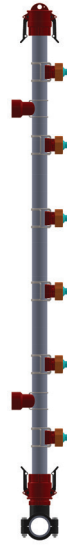

R1B



R2C

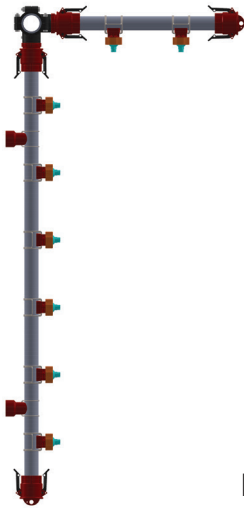

R3T

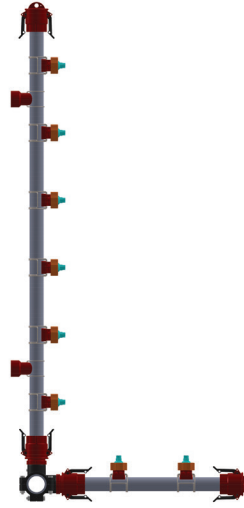

R3B

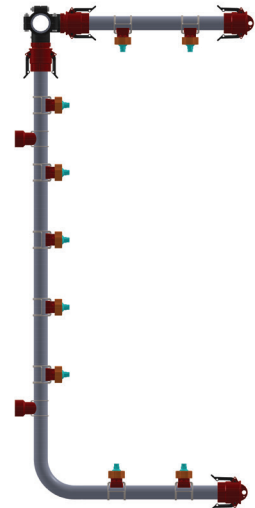

R4T

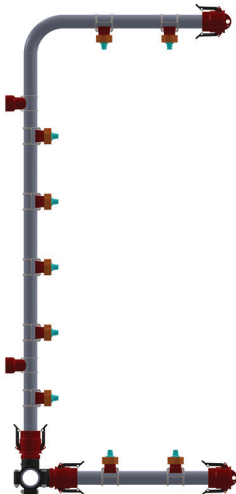

R4B

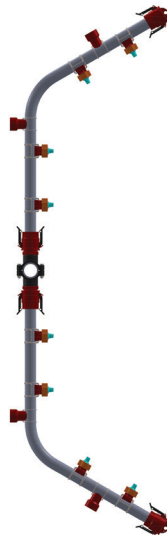

R5C

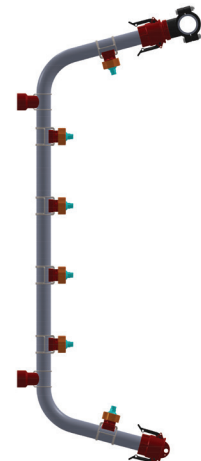

R6T

QUIK-DISCONNECT RISERS - CONTACT US FOR A WORKSHEET

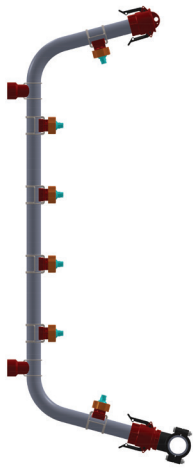

R6B

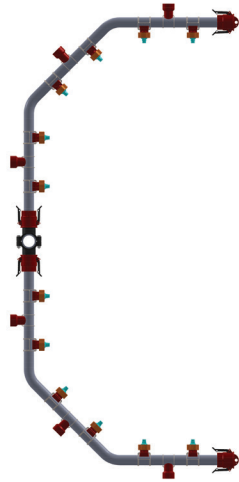

R7C

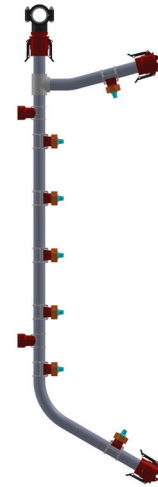

R8T

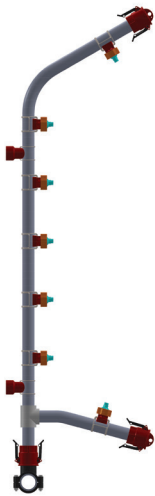

R8B

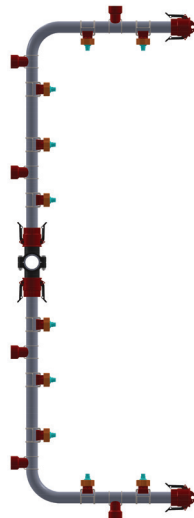

R9C

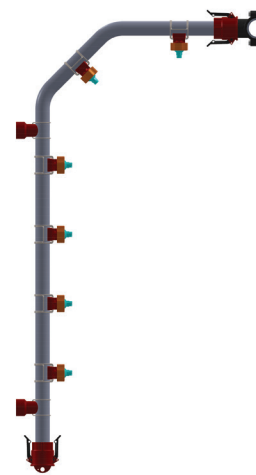

R10T

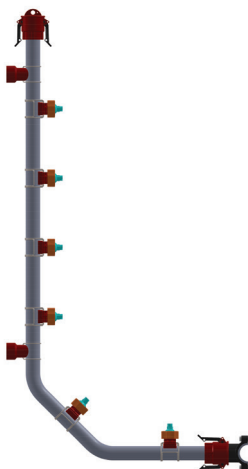

R10B

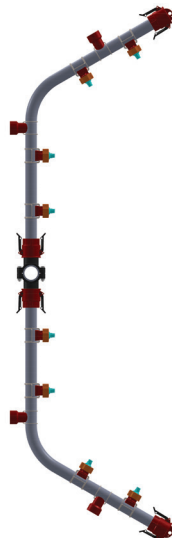

R5C

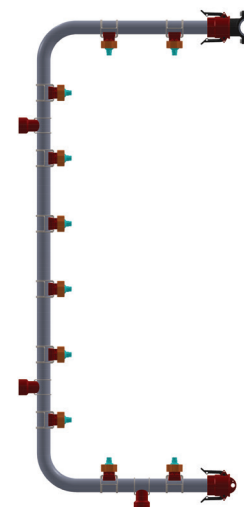

R11T

SEE WORKSHEET SAMPLE, PAGE 39

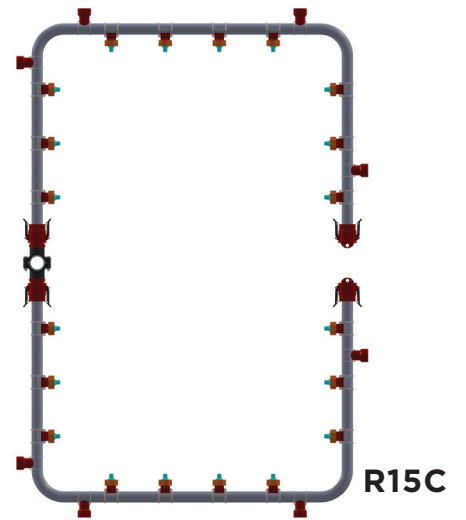
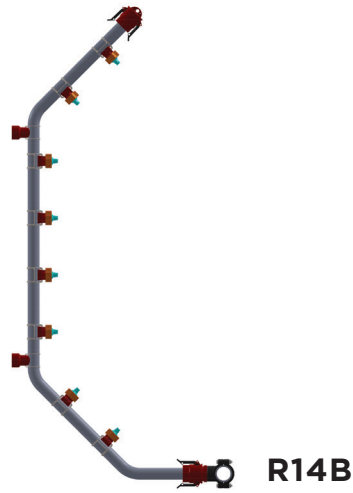
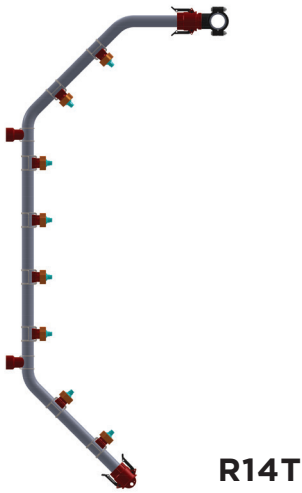
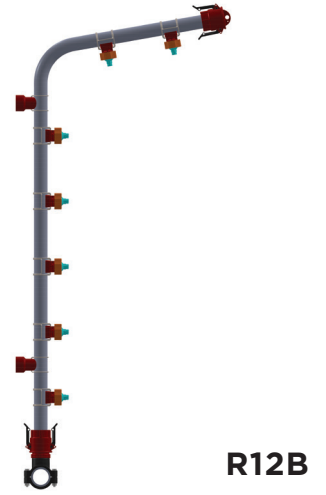
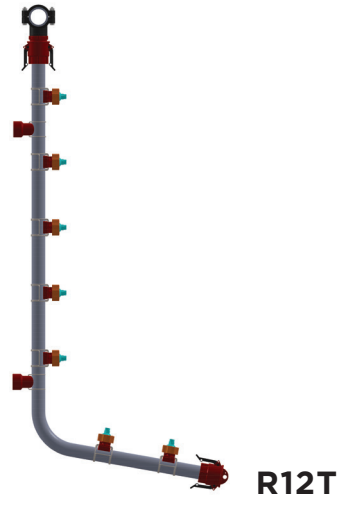
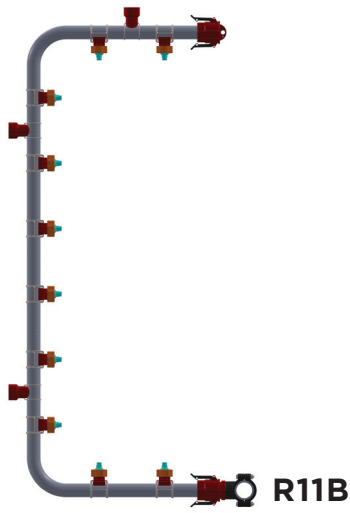

REQUEST A QUOTE ON A UNI-SPRAY CUSTOM-DESIGNED RISER TO FIT YOUR APPLICATION!

UNI-SPRAY SYSTEMS INC.

RISER WORKSHEET

GENERAL INFO

STAGE NO: _____

TANK SIZE (LxWxH): _____

TANK CAPACITY, USG : L: _____

PUMP CAPACITY: _____

OPERATING PRESSURE: _____

HEADER SIZE: _____

TOTAL NO. OF RISERS PER STAGE: _____

RISER INFO

RISER PIPE SIZE: _____

NOZZLE ASS'Y PART NO: _____

TOTAL NO. OF NOZZ'S PER RISER: _____

NO. OF RISER SUPPORTS PER RISER: _____

TOTAL NO. OF RISERS OF THIS TYPE FOR THIS ORDER INCLUDING SPARES: _____

DATE (M,D,Y): _____

NOTES: _____

CUSTOMER: _____

ADDRESS: _____

CONTACT: _____

PHONE: _____

FAX: _____

UNI-SPRAY SYSTEMS INC.
CORPORATE OFFICE:
44 Durward Place,
Waterloo, Ontario, Canada N2L 4E4
Tel: (519) 885-4270 Fax: (519) 885-4325

To Assemble

1. Find the Riser closest to your requirements, on pages 35 to 37 of this catalogue.
2. Call Uni-Spray and we will fax or email you the Riser Worksheet for the Riser style you have selected, such as the sample left (shown full-size on page 39).
3. Fill in all the information boxes, and add any other relevant details. Print clearly with a black pen or pencil. See page 40 for important design considerations.
4. Return the Worksheet to us by fax or email. We will prepare a quotation for evaluation.
5. We will produce a drawing or shop-ready Worksheet Copy of your Riser, and return it to you for confirmation.
6. Check the returned drawing for any changes. Contact us if any changes are required.
7. When the drawing is done to your satisfaction, authorize it with your signature and the date, and return it to us by mail or fax along with your Purchase Order number.
8. Uni-Spray will confirm price and delivery.

ASK OUR EXPERTS

If you have any questions, don't hesitate to call us. Our experts are always ready to help with a special order, even if the Riser style you want is not shown in our current listings.

Tel: +44 (0) 1273 400092

UNI-SPRAY SYSTEMS INC.

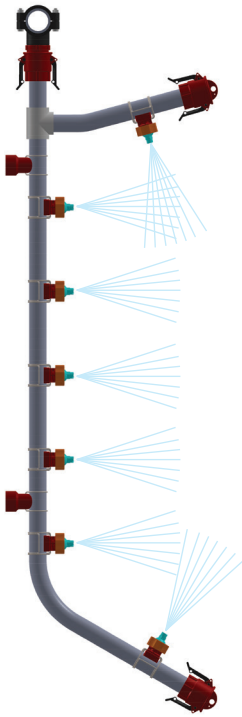

RISER WORKSHEET

GENERAL INFO

STAGE NO: _____
 TANK SIZE (LxWxH): _____
 TANK CAPACITY; USG : L: _____
 PUMP CAPACITY: _____
 OPERATING PRESSURE: _____
 HEADER SIZE: _____
 TOTAL NO. OF RISERS PER STAGE: _____

RISER INFO

RISER PIPE SIZE: _____
 NOZZLE ASS'Y PART NO: _____
 TOTAL NO. OF NOZZ'S PER RISER: _____
 NO. OF RISER SUPPORTS PER RISER: _____
 TOTAL NO. OF RISERS OF THIS TYPE FOR THIS ORDER INCLUDING SPARES: _____

DATE (M,D,Y): _____

NOTES: _____

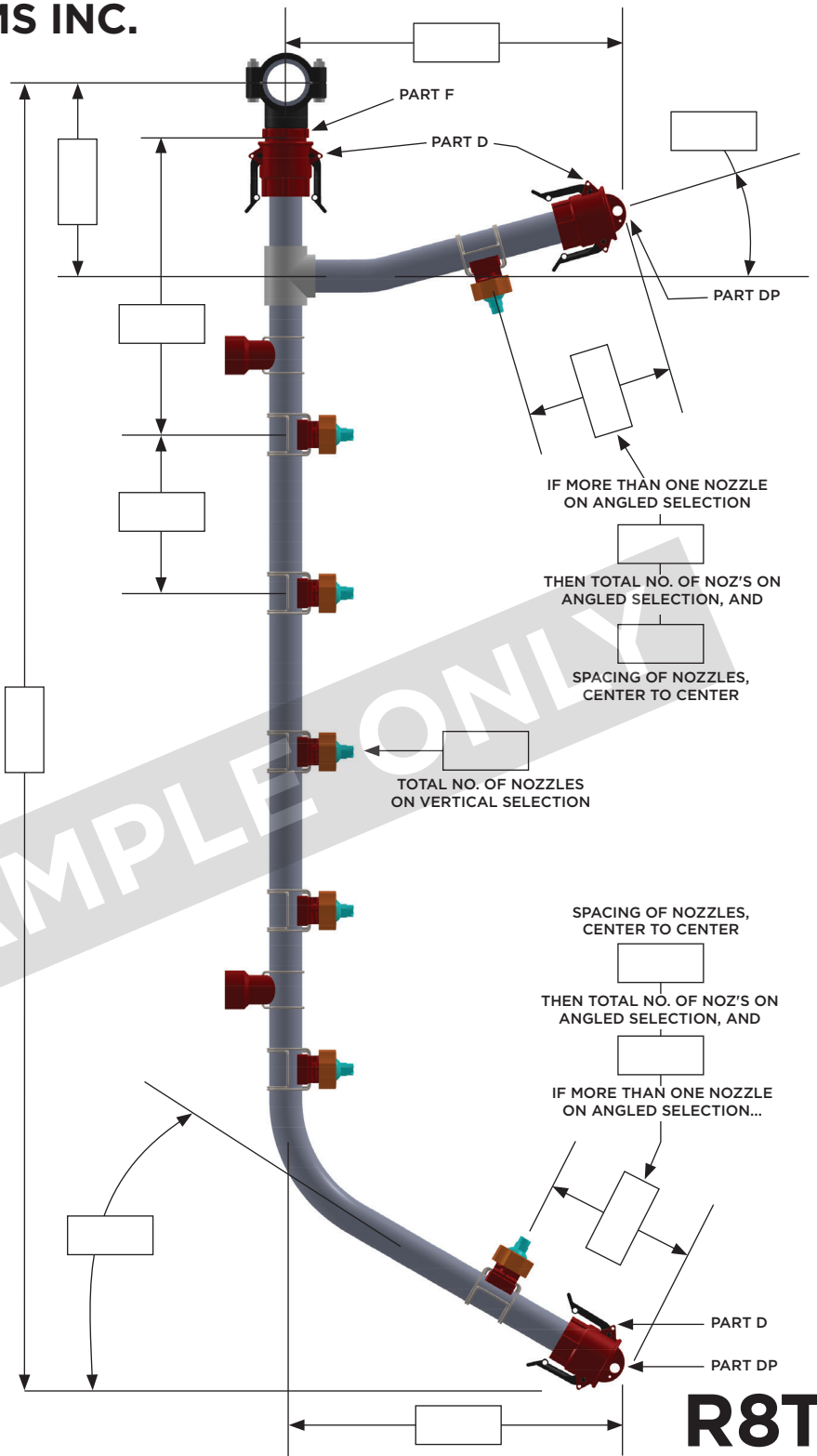

R8T

CUSTOMER: _____

ADDRESS: _____

CONTACT: _____

PHONE: _____

FAX: _____

UNI-SPRAY SYSTEMS INC.

CORPORATE OFFICE:
 44 Durward Place,
 Waterloo, Ontario, Canada N2L 4E4
 Tel: (519) 885-4270 Fax: (519) 885-4325

SPRAY ANGLE SELECTION AND SPACING

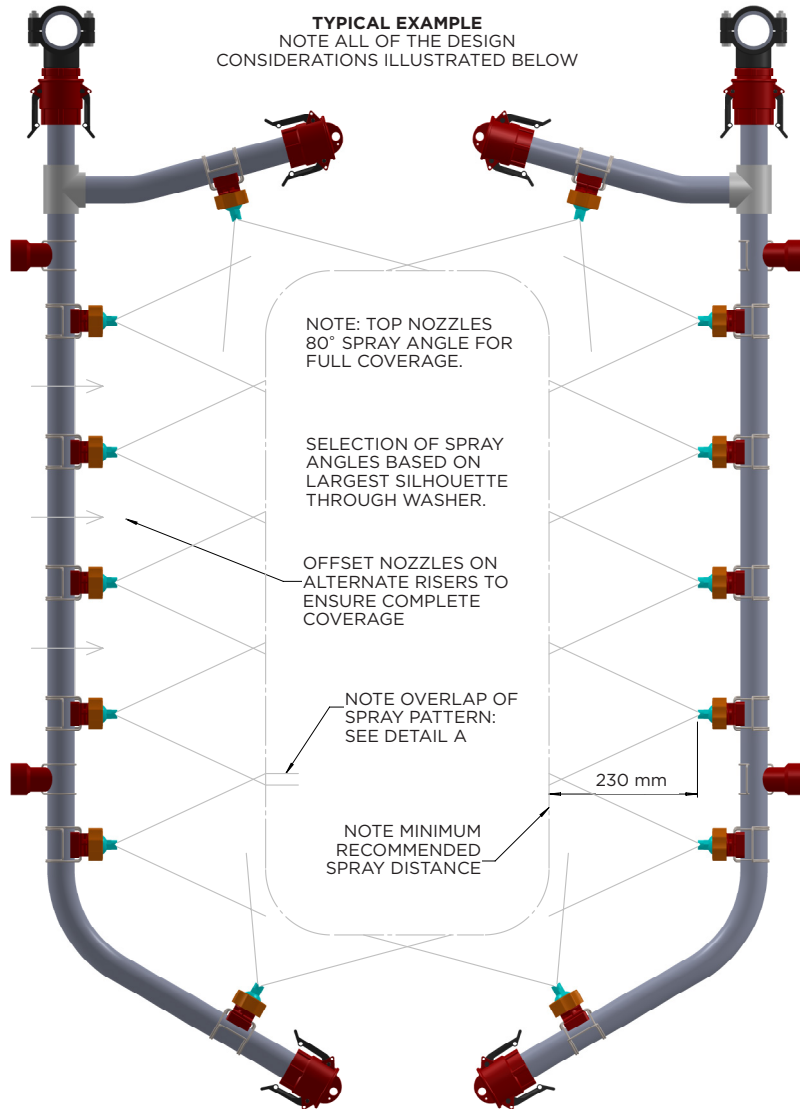

PLEASE NOTE

When selecting Nozzle Spray Angle, and the quantity and distance between nozzles, it is necessary to consider the size and shape of the largest ware that will pass through the washer.

Nozzles must be sized and spaced so that their sprays will cover the entire part, with at least 25 mm overlap between adjacent spray patterns. Sprays should be at least 230 mm from the end of the tip to the part for even coating. The nozzles should be rotated 15° from the Riser axis to avoid interference from overlap spray patterns.

Failure to observe the guidelines may result in poor coating weights and banding.



SPRAY PATTERN

Nozzle Alignment

Note that the flat spray pattern must be rotated 15° from the Riser axis, so that adjacent overlapping spray patterns do not interfere.

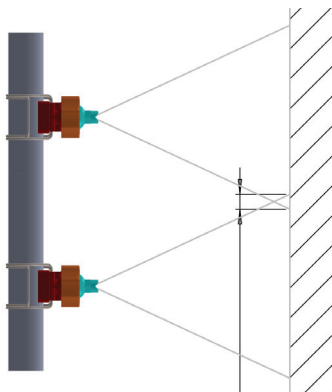

OVERLAP: CORRECT

Detail A: Nozzle Spacing

Select Nozzle Spray Angles and Nozzle Spacing on the Riser so that there is at least a 25 mm overlap between adjacent sprays, as shown at left. This measurement must be obtained using the largest silhouette which must pass through the washer.

Incorrect Spray Angle selection and Nozzle Spacing as shown at right can result in banding.

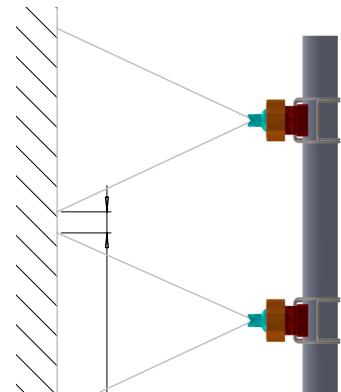

GAP: INCORRECT